

## CHAPTER 23

## Sawing with Stationary Power Machines



## Objectives

After studying this chapter, you should be able to:

- Select stationary power saws for making straight or curved cuts.
- Discuss the proper operation of stationary power saws.
- Choose the most appropriate saw blade for a given operation.
- Maintain stationary power equipment.

## Technical Terms

|                      |                                  |
|----------------------|----------------------------------|
| anti-kickback pawls  | radial arm saw                   |
| band saw             | relief cuts                      |
| beveling             | resawing                         |
| blade guard          | rip fence                        |
| blade guides         | ripping                          |
| blade-raising device | riving knife                     |
| chip load            | saw trunnion                     |
| crosscutting         | scoring blade                    |
| dado                 | scroll saw                       |
| grinds               | sliding table                    |
| guidepost            | splitter                         |
| gullet               | stationary power-sawing machines |
| handedness           | stop                             |
| hook angle           | stop block                       |
| interior cut         | thrust bearing                   |
| miter cut            | tilting-arbor table saw          |
| miter gauge          | tilting device                   |
| outside cut          | U-shaped cut                     |
| overhead guard       |                                  |
| plough               |                                  |

Sawing with stationary power machines is the most fundamental processing operation in cabinetmaking. Cabinetmakers use table saws, radial arm saws, band saws, panel saws, and scroll saws to cut wood and composite materials. Although sawing is also an integral part of other cabinetmaking operations, such as joint making, this chapter focuses on the challenges of sawing to size and shape.

**Stationary power-sawing machines** are designed for either straight-line or curved-line cuts. However, saws used to cut curves can also cut a straight line, if a straightedge or fence is used. Selecting the proper saw involves several decisions:

- Select the safest saw for the cut you want to make.
- Choose an appropriate saw for the cut.
- Have prior instruction and experience with the machine.
- If more than one saw is appropriate, choose the one that is most efficient.

Once you have chosen the machine, consider the following suggestions for safe and efficient operation of the saw:

- With the switch off, disconnect the power and lock out the machine before performing major setup steps, such as changing blades and setting the fence.
- Be sure the saw blade is clean and sharp.
- Install and adjust point-of-operation guards.
- Support material before and after the cut.
- Feed material into the saw properly.
- Ensure dust collection is operating.

## Working Knowledge

Measure accurately. Cabinetmakers are often reminded to “measure twice, cut once.” Remember to check the hook on the end of your tape measure often, especially if it has been dropped. The hook can get bent, resulting in an inaccurate reading.

## 23.1 Handedness

Problems with machine operations can be caused by *handedness*. This refers to whether the user is left or right-handed. In this book, right-handed setups and operations are illustrated. A left-handed person may follow them as shown, or reverse the setups. However, some sawing operations should be set up one way. An example is beveling with the table saw. It is described later in the chapter.

## 23.2 Sawing Straight Lines

Sawing straight lines is a standard operation for reducing stock to workpiece dimensions. Sawing stock square (all corners are 90°) is essential to produce high-quality products. Blade selection is also important. You may be sawing solid wood or composite materials, such as plywood or MDF panels. The proper blade often depends on whether the material has grain or not.

The most accurate straight-line sawing is done on equipment having a circular saw blade. The diameter of the blade helps keep the cut straight. Stationary power saws that use a circular blade include the tilting-arbor table saw, tilting table saw, horizontal and vertical panel saw, beam saw, and radial arm saw. Other specialized stationary machines, such as straight-line rip saws and cutoff saws, use circular blades, but are not discussed here. The maximum recommended blade diameter that can be installed is determined by machine size. Blades vary from 8” to 16” (203 mm to 406 mm) or more, with 10” (254 mm) being most common for table saws.

Material is guided past the blade on tilting-arbor saws or tilting table saws. You must support the material before and after the cut. The saw table may be large enough to do the supporting. However, for long stock or full sheets of manufactured panels, obtain additional supports, such as table extensions, rollers, sliding tables, or another person. The radial arm saw has an advantage over table saws for supporting stock. The material is placed on the table

and the saw blade is pulled through the material. This makes it easier to cut long lumber into shorter lengths.

Material may be too long or heavy to control on some stationary saws. You could cut it to rough size first with a portable circular saw. Full-size sheets of plywood, particleboard, or other composite materials are best cut on either a horizontal or vertical panel saw. Table saws with accessories that extend the capacity of the table may also be used. Some of these accessories are discussed in Chapter 38.

## 23.3 Tilting-Arbor Table Saw

A *tilting-arbor table saw* has either a left-tilting arbor or a right-tilting arbor, depending on manufacturer and model. Some manufacturers make both. The tilting-arbor table saw is also known as a table saw, circular saw, or variety saw. It has the following major components:

- Horizontal table on a machine frame.
- Circular blade that extends up through a table insert.
- Tilting arbor that adjusts the blade angle from 0° to 45°.
- Motor.

There are several features on a table saw. See **Figure 23-1**. The *blade-raising device* changes the blade height. It is usually a handwheel. A *tilting device* changes the blade angle. It is also usually a handwheel. The tilt scale displays the blade angle. Most blade-control handwheels have a lock knob to prevent them from moving, once set.

The switch should be within easy reach at the front of the table. On newer machines, the *on* switch is often recessed into the switch plate. This prevents the machine from accidentally being turned on if someone bumps into the switch plate. The *off* switch is above or next to the switch plate and may be larger for ease of operation. Key-type switches can keep inexperienced operators from running the machine, assuming the key is removed and access to the key is controlled.

Saw manufacturers may offer additional accessories to complement their basic machines. Other manufacturers, called aftermarket providers, offer many accessories that may provide for greater capacity, improved accuracy, and easier material handling. Additional benefits of these accessories are improved safety, and increased efficiency. Several aftermarket accessories are discussed in Chapter 38.

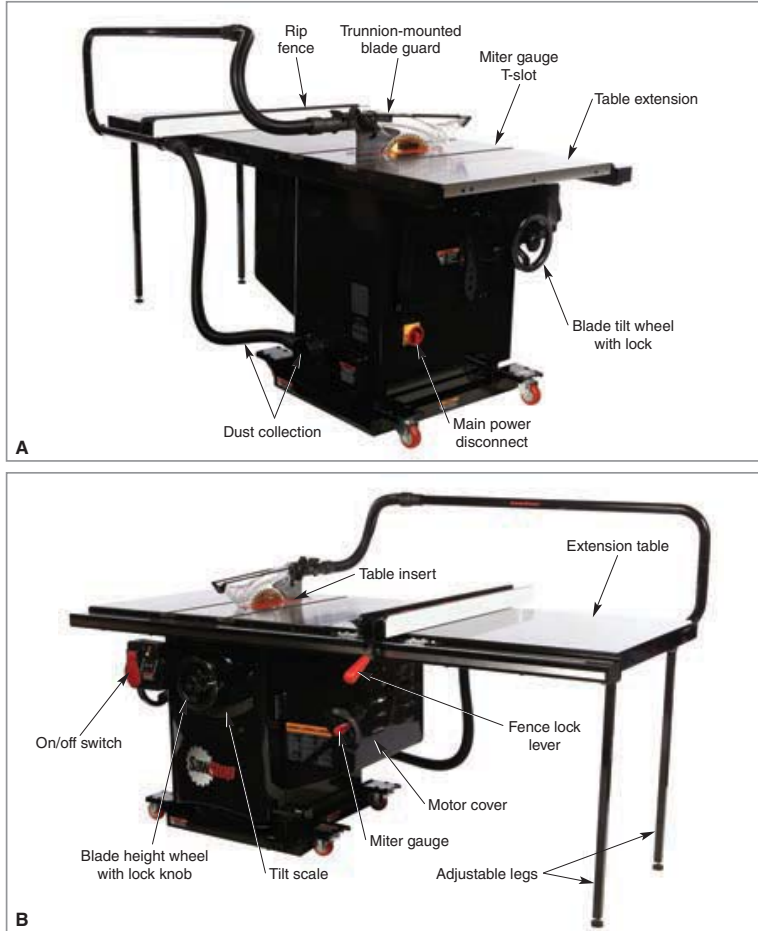

SawStop LLC

Figure 23-1. The table saw has a number of features and adjustments. A—Back view. B—Front view.

### 23.3.1 Guiding Material

When using a table saw, the material must be guided past the blade. A rip fence, miter gauge, sliding table, or jigs and accessories are used to guide the material.

#### Rip Fence

A *rip fence* guides material so it moves parallel to the blade. It is typically in place when ripping stock to width. The fence, on a guide bar or tubes, is locked in place by a fence clamp. A scale may be printed on or etched into the guide bar to help you

set the fence. It may also be equipped with a digital readout device (DRO), **Figure 23-2**. Make minor adjustments for the blade-to-fence distance before clamping the fence.

#### Miter Gauge

A *miter gauge* controls the cutting of narrow workpieces at angles other than parallel to the blade. It is usually adjustable through a 120° swing. Depending on the manufacturer, a 0° or 90° setting positions the gauge perpendicular to the blade for squaring material to length. The miter gauge slides in table slots that are found on either side of the blade. On some machines, these are T-slots. The miter gauge slide has a matching T shape. It can be inserted only at the front edge of the table. The T-slot design keeps the miter gauge from tipping or accidentally being lifted out of the slot.

#### Sliding Table

To improve accuracy when cutting wider workpieces, select a saw with a sliding table or a sliding table accessory. A *sliding table* provides easier handling of large panels. See **Figure 23-3**.

#### Jigs and Accessories

If either the fence or miter gauge will not perform an operation safely and accurately, you may buy or build a jig to hold the workpiece and guide the tool. User-made jigs must be sturdy and hold the workpiece firmly. Make the jig of solid stock, plywood, or fiberboard. It might clamp to the rip fence or miter gauge. You can also attach wood strips to the jig bottom so it slides in both table slots.



Patrick A. Molzahn

Figure 23-2. A rip scale may be supplemented with a digital readout (DRO).



Laguna Tools

Figure 23-3. This aftermarket sliding table can be added to most table saws to make crosscutting easier.

Commercially available accessories include tenoning jigs and sliding table attachments. Refer to Chapter 38.

### 23.3.2 Blade Guards

A *blade guard* is an essential accessory because it keeps your hands away from the blade and helps control sawdust. It may mount on the saw trunnion or attach to the table edge.

A trunnion-mounted guard is bolted to the *saw trunnion*, **Figure 23-4**. This is the main machine



SawStop LLC

Figure 23-4. This blade guard is mounted to the saw trunnion under the table.

part that supports the motor and blade. When you change the blade angle, the guard also tilts. The assembly consists of the blade guard, splitter, and anti-kickback pawls. The guard rests over the blade and is hinged to the splitter. The *splitter* keeps the saw kerf open as the cut is made. Without a splitter, stock that warps during the cut could squeeze against the blade and bind the saw. The stock might then be thrown back toward you. With a splitter-type guard, you must saw completely through the material.

If the material binds, *anti-kickback pawls*, attached to the splitter, should prevent the material from being thrown back at the operator. The pawls ride on top of the stock after it passes the blade. If the material binds during the cut, the pawls dig in to stop it from being kicked back.

If the material becomes difficult to feed, hold it against the table with a push stick or by hand. With your other hand, reach down and turn off the power. Wait until the saw stops to remove the material.

An *overhead guard* attaches to the edge of the saw table. See [Figure 23-5](#). It is adjusted independently of the blade. This type of guard may be used with either a splitter or a riving knife. A *riving knife* is a curved, steel plate mounted behind the blade. The knife functions much like a splitter except that it is not equipped with anti-kickback pawls, [Figure 23-6](#). Riving knives are preferable because they are less obtrusive and can remain in place when cutting grooves. Riving knives must be properly adjusted to function correctly. They should be approximately 1/16" (1.5 mm) below the top of the blade, and slightly thinner than the kerf.



Acacia

**Figure 23-5.** Blade guards may be mounted to the table edge.

### 23.3.3 Installing Saw Blades

Circular saw blades are categorized by tooth design, kerf width, arbor hole size, and other features. The blade may also be categorized according to the grain direction or material it cuts. For example, a rip blade is designed to cut along the grain. A crosscut blade is designed for cuts across the grain. Combination blades do both. A more detailed discussion of blade design and selection is given later in the chapter.

#### Procedure

##### Saw Blade Installation

Install saw blades as follows:

1. With the switch off, disconnect the power and lock out the machine.
2. Remove the table insert (and blade guard, if necessary).
3. Raise the blade so the nut on the arbor can be reached easily.
4. Some saws have arbor locking mechanisms, while others use a double wrench system, [Figure 23-7](#). If your saw has neither of these, place a wrench on the nut and wedge a piece of softwood in between the blade and the saw's surface to loosen the nut.
5. Pull the wrench toward the front of the saw to loosen the nut.
6. Remove the nut, arbor washer, and blade.
7. Remove any pitch, gum, or rust from the arbor, flange, arbor washer, and nut with solvent and fine steel wool.
8. Install the replacement blade with the teeth pointing toward the front of the table (in the direction of blade rotation).
9. Install the arbor washer and thread the nut on finger-tight.
10. Tighten the nut with the wrench. While standing behind the machine, push the wrench toward the back of the saw table. Use the arbor lock, wrenches, or wedge a piece of softwood lumber between the blade and the saw's surface to keep the blade stationary. Be careful not to damage the teeth on the blade.
11. Replace the table insert and guard.

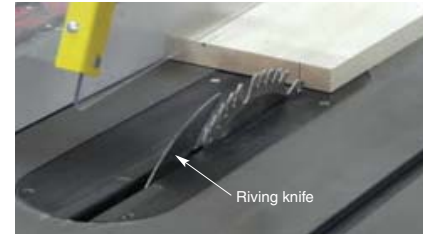

Patrick A. Molzahn

**Figure 23-6.** The riving knife is installed behind the blade to prevent stock from pinching the blade after it is cut.



Patrick A. Molzahn

**Figure 23-7.** To remove the arbor nut, pull the wrench while standing in front of the machine.

#### Working Knowledge

Inadequately tightening the nut can result in excessive vibration from the blade and a dangerous condition. Tighten the nut securely.

#### Safety Note

When working on any tool or machine that has a power source (pneumatic, electric, or hydraulic) or stored energy, the tool or machine must be locked out according to OSHA requirements. If the person working on the machine is doing minor tool changes or minor servicing during normal production operations and has control of the plug on a single power source tool or

machine, they are not required to put a physical locking device on the plug. However, if the machine is left unattended, it must be physically locked out. A lock, often accompanied by a specialized hasp, is placed on the machine to prevent accidental startup.

### 23.3.4 Setting Up a Table Saw

Saw setup includes deciding whether to use the rip fence or miter gauge, setting the blade height, and squaring the blade.

The following guidelines should help you decide whether to use a rip fence or miter gauge.

As shown in [Figure 23-8A](#), use the rip fence when:

- The saw cut will be longer than the distance from the blade to the fence.
- The workpiece will pass between the fence and the blade. Hold and feed stock with push sticks when the blade-to-fence distance is less than 4" (100 mm).

As shown in [Figure 23-8B](#), use the miter gauge when:

- The saw cut is shorter than the length of the material.
- The saw cut will be shorter than the distance from the blade to the front edge of the table.

Use the rip fence and miter gauge only when:

- The blade height is less than the material thickness. In this case, the material is not cut off. This might occur when making certain joints, [Figure 23-9](#). Refer to Chapter 37.
- The rip fence supports a stop block for sawing duplicate parts of equal length. The stop block provides clearance between the workpiece and the fence to prevent the offcut from becoming wedged between the blade and the fence.

#### Procedure

##### Setting Blade Height

To set blade height, proceed as follows:

1. With the switch off, disconnect power to the saw and lockout the machine.
2. Loosen the blade-raising handwheel lock knob.
3. Rotate the blade by hand so a tooth is pointing vertically.



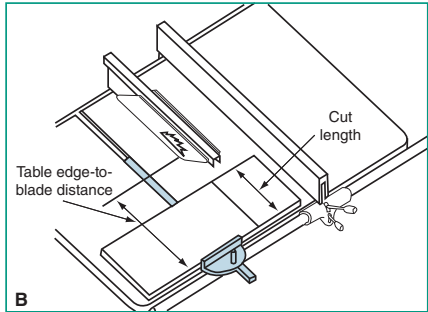
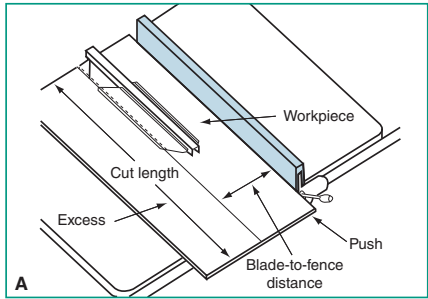

Goodheart-Willcox Publisher

**Figure 23-8.** A—The rip fence is used when the blade-to-fence distance is less than the cut length. B—Use a miter gauge when the material width is less than the distance from the blade to the table edge.

4. Hold a measuring device near the blade and adjust the height. A blade height gauge is designed for this. See **Figure 23-10**.
5. Tighten the lock knob.

### Squaring the Blade

For cuts other than bevels, the blade must be at 90° to the table. Check the blade angle between saw setups and after blade changes. Place a square on the table and against the blade. See **Figure 23-11**. The square should rest between the teeth. Loosen the arbor tilt lock and adjust the angle until the square rests flush against the blade body. Tighten the arbor tilt lock.



Chuck Davis Cabinets

**Figure 23-9.** Both the rip fence and miter gauge may be used for cuts that do not go completely through the material. A dado cut is shown. The guard has been removed to show this operation.



Patrick A. Molzahn

**Figure 23-10.** Blade height is set easily with this gauge.



Chuck Davis Cabinets

**Figure 23-11.** Check to ensure the blade is at 90° to the table. Avoid placing the square against the saw teeth.

## 23.3.5 Operating the Table Saw

The table saw is capable of performing many different operations. Those discussed here are ripping, crosscutting, beveling, mitering, resawing, and cutting dados. Other operations, discussed in other chapters, include compound mitering, shaping, tapering, and joint making.

### Ripping Lumber

**Ripping** is cutting lumber along the grain. See **Figure 23-12**. Install a carbide-tipped rip blade. Set the blade height at least 1/4"–1/2" (6 mm–13 mm) above the material thickness. At least two teeth should always be in contact with the wood. Unlock and move the rip fence to the desired width. Measure from the fence to a tooth set toward the fence. It is better to measure twice and saw once than to measure once and need to saw twice. Finally, make sure the blade guard and riving knife or splitter are in place.

Stock to be ripped must have one flat face and one straight edge. The face rests on the table and the edge rides against the rip fence. Turn on the saw and feed the wood past the blade. Hold it firmly on the table and against the fence. Make sure long lengths of material are supported. Stand to one side

of the cutting line. Keep your hands at least 3"–4" (75 mm–100 mm) from the blade. For narrow stock, use a push stick.

Remember that wood may warp while being ripped. This happens because ripping relieves internal stresses. A splitter or riving knife is designed to prevent sawn lumber from pinching the blade. However, maintain a firm hold and be prepared for kickback in case feeding the material becomes difficult. Always stand to either the left or right side of the material's possible path so you are out of harm's way if it suddenly becomes a projectile. Remember to always push the stock past the blade.

### Ripping Plywood

Plywood, a stable manufactured product, is ripped along the face grain like solid wood. See **Figure 23-13**. Install and use a carbide-tipped rip or combination blade. Set the blade height 1/4"–1/2" (6 mm–13 mm) above the panel thickness. With the guard and splitter in place, adjust the rip fence and saw the plywood as if you were ripping solid stock.

### Crosscutting Lumber and Plywood

**Crosscutting** is sawing through the wood or plywood across the face grain. See **Figure 23-14**. Install a carbide-tipped crosscut blade. Set the blade height so the entire carbide tip is 1/4"–1/2" (6 mm–13 mm) above the workpiece.

The material is typically guided with a miter gauge positioned in the left table slot. This is the normal cutting position for a right-handed person. Mark the cut to be made. Hold the workpiece firmly against the gauge with your left hand while feeding with your right hand. With the saw off, align the cutting line with the blade. Make sure the width of the

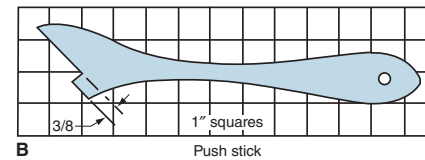

Patrick A. Molzahn; Goodheart-Willcox Publisher

**Figure 23-12.** A—To rip narrow widths, use push sticks to hold and feed the material. B—Dimensions for a typical push stick.



Patrick A. Molzahn

**Figure 23-13.** Ripping plywood.



Patrick A. Molzahn

**Figure 23-14.** Crosscutting with a miter gauge. Note the clean backer board to mark the exit of the cut and prevent tearout.



Patrick A. Molzahn

**Figure 23-15.** Cutting parts to length using a stop mounted to the miter gauge.

blade is on the waste side of the cutting line. Pull the workpiece back so it does not touch the blade. Start the saw and feed the stock to make the cut.

The face of most miter gauges is about 6" (150 mm) wide and 2"–3" (50 mm–75 mm) from the blade. Many times this is not close enough to the blade to support short parts. Fasten an auxiliary wood face to the miter gauge that extends past the blade. Attach abrasive paper to the wood face to help grip the work. Short workpieces can then be easily crosscut.

It is sometimes difficult to use a miter gauge for crosscutting to length. If the workpiece width is larger than the distance from the blade to the table edge, use a radial arm saw, portable circular saw, or panel saw.

### Crosscutting Duplicate Parts to Length

There are two methods for cutting a number of workpieces to equal lengths. Use a stop with either the miter gauge or the rip fence.

#### Miter Gauge with Stop

A *stop* is attached to the miter gauge, **Figure 23-15**. To adjust the stop, mark the desired length on the first part to be cut. Align the mark with the saw blade, and then butt the workpiece to the stop. Make a test cut and adjust the stop position as needed. Sliding table accessories may be equipped with an easily read scale for positioning the stop, **Figure 23-16A**. This eliminates measurement errors and provides for repeatability in later operations. See **Figure 23-16B**.



Chuck Davis Cabinets

**Figure 23-16.** A—An accessory sliding table has a 72" (1.83 m) scale and stop for cutting parts to length. B—Use an adjustable stop attached to a sliding table for cutting duplicate panel parts to length. Guards are removed to show the procedure.

### Stop Block

A *stop block* may be clamped to or placed against the rip fence. See **Figure 23-17A**. A miter gauge and fence should not be used together for cutting parts to length. The cutoff portion of the workpiece can bind between the blade and fence and possibly be thrown back at the operator. A stop block provides clearance. Use a 1" (25 mm) block to provide adequate clearance and to ease setting of the cutting length using the rip scale. The cutting length is the distance read on the rip scale less the thickness of the stop block. Alternatively, the cutting length is the distance from the block to a tooth on the blade set toward the fence. Measure and set the cutting length with the stop placed tightly against the fence beside the blade, **Figure 23-17B**. Reclamp the stop several inches in front of the blade. Guide your work with the miter gauge.



Patrick A. Molzahn

**Figure 23-17.** A—A stop block next to the rip fence determines the length of parts cut to duplicate lengths. B—Add the desired length of the parts to the thickness of the stop block and set the rip fence scale to the total. Guards are removed to show these procedures.

### Sawing Nongrain Manufactured Products

Many applications use MDF, particleboard, fiberboard, and similar materials. The cores of these composites lack a grain pattern.

Depending on the smoothness of cut required, extra care may be necessary. MDF that is to be painted with a high-gloss, opaque polyurethane requires a smooth finish. Select a blade with teeth that have an alternate top bevel grind. This type of blade is discussed later in this chapter.

Panels with wood veneer will require the same rip and crosscut considerations as solid stock. Set the blade height so that the entire carbide tip is 1/4"–1/2" (6 mm–13 mm) above the material thickness. Make a test cut to determine if the material tears out on the underside of the workpiece. Adjust the blade height up or down to find the height at which the tearout is minimized. Use the rip fence or miter gauge as for sawing solid stock.

Many panel saws are equipped with scoring blades to prevent tearout. A small diameter blade prescores the underside of the material before the main blade separates the panel.

### Beveling

*Beveling* is sawing with the blade tilted. This is typically done as a joint making or shaping operation. On most table saws, the blade tilts up to 45° in one direction only. Some manufacturers build two models of the same saw; one tilts to the left and the other tilts to the right. For saws equipped with an accurate tilt scale, set the angle with the scale. Otherwise, the blade angle can be set with a T-bevel, protractor, or triangle. Plan beveling



Patrick A. Molzahn

**Figure 23-18.** Set the T-bevel angle with a protractor and then set blade tilt.



operations so the blade tilts away from the fence or miter gauge. This will create cleaner cuts on the top surface because the blade's teeth will enter at what will be the outside corner, leaving any chipping or tearout for the inside corner. You want the waste to remain on the table below the blade. If the table tilts toward the miter gauge or fence, the offcut can fall onto the moving blade and kick back.

With a bevel cut edge, workpiece dimensions will differ on the top and bottom faces. Usually, the longer of the two faces is dimensioned on the drawing. It is difficult to set the rip fence or position the workpiece accurately against the miter gauge for a bevel. You should estimate the dimension and make a test cut before making the final cut.

For ripping bevels, estimate the distance from the blade to the fence. See **Figure 23-19A**. Start a saw kerf no more than 1" (25 mm) into a test piece that has been surfaced and squared. Measure the width and make adjustments so the workpiece will be the desired width.

For crosscut beveling, it is best to make test kerfs on the waste side of your cutting line. See **Figure 23-19B**. Reposition your work against the miter gauge after each kerf until the cutting line aligns with the blade. A clean backer board will show the exact location of the cut and reduce tearout.

### Mitering

**Miter cuts** are made with a miter gauge, **Figure 23-20**. The blade is set square to the table. Adjust the miter gauge to the required angle. For sawing stock at angles up to 45°, install a crosscut blade. For angles greater than 45°, a rip blade may be more effective.

Workpieces tend to "creep" along the face of the miter gauge when sawing. To prevent this, fasten an abrasive-covered wood auxiliary fence to the miter gauge.

### Green Note

Tool coatings have been developed that help reduce friction when sawing and shaping wood products. Reducing friction reduces heat, which extends tool life. Less friction also reduces the amount of energy required to run machinery.

### Resawing

**Resawing** creates two or more thin pieces from thicker wood on edge. This helps conserve wood. For example, two 1/4" (6 mm) thick boards can be cut

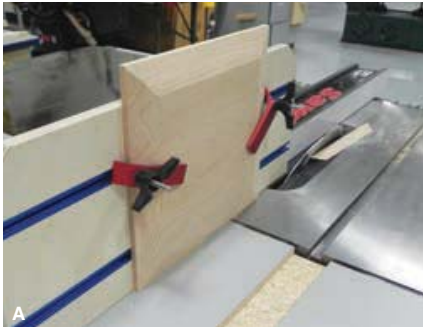

**Figure 23-19.** When beveling, feed stock so the excess falls off below the blade. Guards have been removed to show the operation. A—Ripping. B—Crosscutting.



**Figure 23-20.** Sawing a miter.

Patrick A. Molzahn

Patrick A. Molzahn

from 3/4" (19 mm) stock. Depending on the width of the board, one or two passes may be required to resaw with the table saw. If the material width is less than the maximum blade height, resawing can be done with one pass, **Figure 23-21**. If the stock width is greater than the maximum blade height, two passes are required. Cut just over halfway through on the first pass. See **Figure 23-22A**. Turn the material over with the same face against the fence. Separate the two pieces with a second pass. Use the planer to bring the workpieces to final dimension.

A traditional blade guard cannot be used during the first pass of a two-pass resawing operation. A trunnion-mounted guard will not allow the material to feed past the splitter. An overhead guard would also interfere. An alternative, side-mounted guard



**Figure 23-21.** A one-pass resawing operation. Use push sticks to feed the material as your hand nears the blade. Guards are removed to show procedure.

Chuck Davis Cabinets

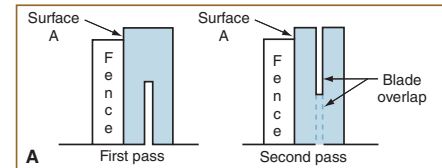

**Figure 23-22.** A two-pass resawing operation. A—Set the blade height just over half the material width. Keep the same surface against the fence for both passes. B—Use push sticks to feed the material as your hand nears the blade.

helps protect the operator. Make sure it does not interfere with the operation. Keep your hands away from the area around the blade by using push sticks. See **Figure 23-22B**.

### Procedure

#### Two-Pass Resawing

The two-pass resawing procedure is as follows:

1. With the switch off, disconnect power to the saw.
2. Adjust the blade to 1/4" (6 mm) higher than half the height of the stock.
3. Lock the blade height and tilt adjustments.
4. Adjust the fence so that the blade will separate pieces of equal thickness.
5. Position an alternative guard to shield the operator.
6. If the material is more than 36" (914 mm) long, plan to have help or outfeed support.
7. Make the first pass. Use push sticks when the end of the material comes to within 12" (300 mm) of the blade.
8. Be cautious when the material clears the blade. Have a firm footing and stand to one side of the cutting line. Keep your eye on the blade as you withdraw your hands and push sticks.
9. Turn the material over end-for-end and feed it through with the same face against the fence.



Chuck Davis Cabinets

### Ripping Narrow Strips

Narrow strips of wood are often used for inlay work. Always use push sticks when ripping material less than 4" (100 mm) wide. Extremely narrow strips, for example less than 1/2" (13 mm), present an even greater challenge. It is difficult to guard the operation, and they are more prone to kickback. There are two ways to rip these pieces. The first way requires a zero-clearance throat plate and a sacrificial push stick. The stock is ripped in the normal manner, with the push stick backing up the cut at all times. See **Figure 23-23A**. The zero-clearance throat plate prevents the stock from becoming wedged in the throat opening. You can make your own or purchase blank throat plates.

The second method avoids the issues noted above by positioning the narrow strip on the offcut side of the blade. A stop block is positioned before the blade to obtain multiple strips of equal width. See **Figure 23-23B**. The main disadvantage of this method is that the fence must be readjusted with each pass. However, traditional guards can be used and there is no danger of the stock getting jammed between the blade and the throat plate.

### Cutting Dados and Ploughs

Table saws can be equipped with a stacked set of blades called a dado set. They consist of a left and a right main blade, and a series of chipper blades of varying thickness. By selecting different combinations of chipper blades, grooves can be cut from 1/4" to 13/16" (6 mm to 21 mm) wide. When cut with

the grain, wide grooves are called *ploughs*. When cut perpendicular to the grain, they are known as *dados*. See **Figure 23-24**.

#### Safety in Action

##### Using the Table Saw

- Wear approved eye protection.
- Remove jewelry; secure long hair and loose clothing.
- Stand in a comfortable position and to the side of the blade path.
- With the switch off, disconnect the power and lock out the machine before making repairs or removing or installing a blade.
- Always use a blade guard when ripping or crosscutting.
- Make sure that the blade teeth are pointed forward and the nut is tight.
- Tighten the fence clamp or miter gauge adjusting knob.
- Make sure the table insert is flush with the table.
- Blades should be sharp, properly set, and free of resin.
- Always think through an operation before performing it.
- Hold the stock firmly against the fence or miter gauge.

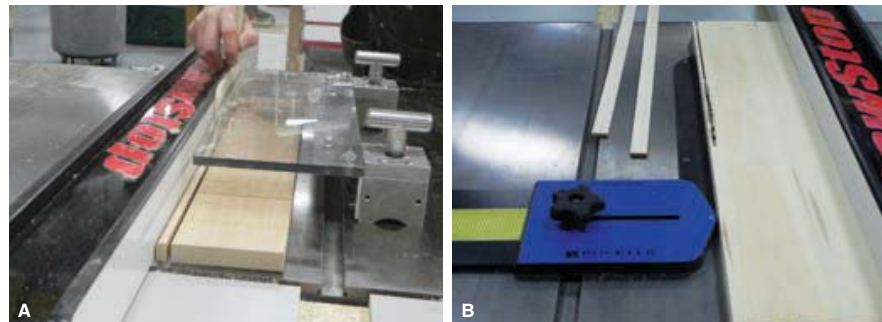

Patrick A. Molzahn

**Figure 23-23.** Ripping narrow strips. A—The narrow strip is positioned between the fence and the blade. A push stick must be used to back up the strip. B—Narrow strips are cut on the outside of the blade. A stop block is positioned for readjusting the fence to the correct point for repeat cuts. The guard has been removed to show the procedure.

- Use a push stick for ripping material narrower than 4" (100 mm).
- Never operate a saw without using a miter gauge, rip fence, or other accessory to guide the material.
- Adjust the saw blade to the appropriate height above the workpiece.
- Never reach across, over, or behind the blade.
- Do not use the rip fence as a cutoff guide. Clamp a clearance block to it.
- Move the rip fence out of the way when crosscutting.
- Stop the machine before attempting to free work that is caught in the machine.
- Provide support for a long or a wide workpiece before, during, and after the cut.
- Do not look around when making a cut. Concentrate on the point of operation. Always keep your fingers at least 3" away from the blade.

## 23.4 Tilting Table Saw

On some circular saws, the table tilts instead of the saw arbor. Multipurpose woodworking machines (Chapter 38), modern imports, and some older equipment may be equipped with a tilting table. Most operations, with the exception of beveling, work in the same way as on the tilting-arbor table saw. When tilting the table for beveling, follow these guidelines:

- Have the workpiece below the blade when using the rip fence. See **Figure 23-25A**. Prevent offcut

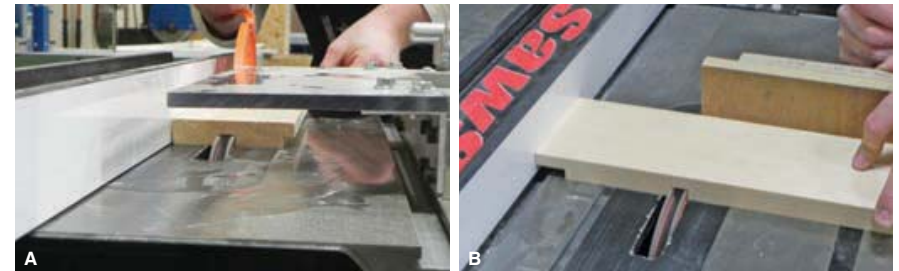

**Figure 23-24.** A—Stock is being cut with a dado blade with the grain. This is known as a plough cut. B—The miter gauge is used to "dado" the stock across the grain. The rip fence is being used as a stop. This is permissible because the stock is not being cut through, so there will be no offcut released. The guard has been removed to show the procedure.

- material from sliding into the blade. Another person may need to help you with long stock.
- Have the workpiece above the blade when using the miter gauge. See **Figure 23-25B**. The offcut will slide away from the blade after the cut is complete.

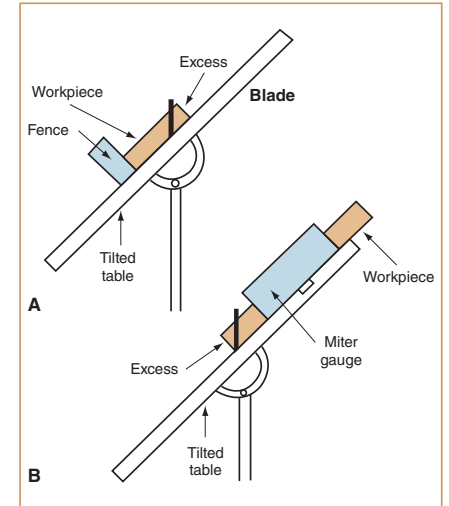

Goodheart-Willcox Publisher

**Figure 23-25.** A—Rip fence beveling. With the table tilted left, the stock will rest against the fence when ripping. B—Miter gauge beveling. With the table tilted left, the offcut will release and fall away when crosscutting.



## 23.5 Sawing Panel Products

Handling large and bulky materials is often a problem for cabinetmakers. Panel products are one example. They may be large, thin, and flexible, or thick and heavy. Handling these materials may require two people or a specialized vacuum lift. To cut full-size sheets, most cabinetmakers use a panel saw rather than a table saw.

Horizontal and vertical panel saws are available. See **Figure 23-26**. The panel is supported by a sliding table. The material is fed into the blade by moving the table forward. The disadvantage of sliding panel saws is that they take up a great deal of space. A vertical panel saw can be placed up against a wall. The panel is placed in the frame and the saw is pulled through the cut. See **Figure 23-27**.

Another type of saw for cutting panels is known as a beam saw, **Figure 23-28**. Beam saws are usually found in shops that process at least fifty sheets of material per shift. Many beam saws can cut upward of six sheets at one time. Material moves easily over a bed of air. The panels are clamped in place, and the saw blades travel along a guide system to make accurate cuts.



Fremont Interiors, Inc.

**Figure 23-26.** Horizontal panel saws are useful for breaking down sheet goods. This panel saw is equipped with a numeric control that stores cutting lists and controls the rip fence, crosscut stops, and all blade adjustments.



Patrick A. Molzahn

**Figure 23-27.** Vertical panel saws are used to break down large sheets. They can be equipped with scoring blades to reduce tearout and their small footprint saves space.

### 23.5.1 Scoring Blades

Regardless of the type of panel saw, scoring blades are needed to create tear free cuts in panel materials. A *scoring blade* is a small diameter blade designed to precut, or score, the material before the main blade cuts through the panel. Scoring blades are designed to penetrate just through the face of the material, no more than about  $1/40^{\circ}$  (1 mm). Their cut is slightly wider than the main blade. See **Figure 23-29**.

## 23.6 Radial Arm Saw

The *radial arm saw* was originally used for sawing, surfacing, drilling, shaping, and sanding, **Figure 23-30**. Most radial arm saws are now used primarily for sawing stock to length. Imagine trying to crosscut a 12' (3.66 m) long piece of lumber with a table saw. This task is more easily done with a radial arm saw.

The radial arm saw blade, blade guard, and motor are above the table. All of these are mounted on a yoke that moves forward and backward on an arm. The arm swings both left and right for mitering. The motor assembly can be tilted for bevels. The entire frame can be mounted on legs or a bench. Radial arm saws are sized according to blade diameter, from 8" to 16" (203 mm to 406 mm), with 10" (254 mm) being the most common.



Casadei Busellato

**Figure 23-28.** Beam saws are capable of processing multiple sheets at a time. Material is usually loaded from the back of the machine. When it is ready to be cut, pusher arms move it into place and the saw travels along a carriage to make the cut.

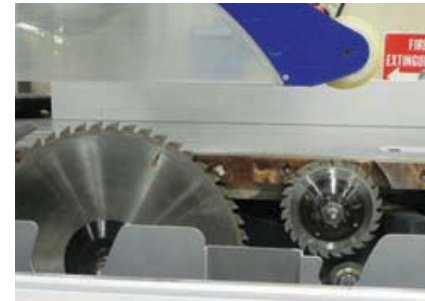

Patrick A. Molzahn

**Figure 23-29.** Scoring blades are located in front of the main blade. They precut the underside of brittle materials to prevent tearout as the main blade exits the cut.

### 23.6.1 Changing the Blade

Change blades when the blade is dull or when setting up for a different sawing operation. Radial arm and table saws may use the same types of blades. However, the radial arm saw has less tendency to climb if the blade has a face hook angle of  $5^{\circ}$  or less.



Delta International Machine Corp.

**Figure 23-30.** A variety of features and adjustments are found on the radial arm saw.



To change the blade, first remove the guard. Secure the motor arbor so you can loosen the arbor nut. There may be a hex hole in the end of the shaft for an Allen wrench. There could be two flat surfaces behind the blade for an open-end wrench. If you do not see a method for holding the arbor, clamp a hand screw to the blade above the teeth. Remove the old blade and place the new blade with the teeth pointed toward the fence. See [Figure 23-31](#).

Once the blade is installed, tighten the arbor nut securely. Do not overtorque the nut. This could strip the threads.

### 23.6.2 Saw Setup

The versatility of the radial arm saw comes from its wide range of adjustments. The elevation crank, found on the column or machine frame, raises and lowers the arm. This sets the blade height. The arm pivots at the column to position the blade for miter cuts. The yoke rotates on the arm to position the blade parallel to the fence for ripping. The motor pivots 90° within the yoke for beveling. A locking mechanism is provided for each of these settings. The only machine part that can move during saw operation is the yoke. It slides back and forth on the arm for crosscutting and mitering. This setting, too, is locked for certain procedures, such as ripping. With all of these adjustable features, the radial arm saw must be frequently monitored to check that each adjustment remains true.

#### Crosscutting

The radial arm saw is well suited for crosscutting lumber and wood products. See [Figure 23-32](#). Lock the arm in the 0° position. Lock the yoke pivot and bevel at 0°. With your left hand or a clamp, hold the material stationary against the fence away from the cut.

With the machine off, pull the blade until it touches the workpiece. Align the blade to the excess side of the cutting mark. Then, back the blade off and start the motor. Grip the handle. Pull the saw across the material just far enough to complete the cut. Then push the saw back through the kerf past the fence. Turn the saw off and wait for the blade to stop. Then remove the workpiece and offcut.

To determine the maximum material width you can cut in a single pass, pull the saw out to its farthest travel and measure from the fence to the point where the blade touches the table. This distance may vary from 12" to 24" (305 mm to 610 mm).

If your saw is not equipped with a self-retracting system, you will need to push the saw back against



Goodheart-Willcox Publisher

**Figure 23-31.** Changing a radial arm saw blade.



Patrick A. Molzahn

**Figure 23-32.** Crosscutting with a radial arm saw.

the column. Retractor systems automatically return the saw to its normal resting position next to the column when the operator finishes the cut. Do not let go of the saw until it has returned to its resting point.

#### Crosscutting Multiple Parts

Cut multiple parts to length by attaching a stop. See [Figure 23-33](#). Clamp it to the fence at the desired distance from the blade. Place each workpiece against the stop and make the cut. Turn the stop's adjusting screw to make minor changes in distance to the blade. If you do not have a stop, you can clamp a block of wood to the fence. See [Figure 23-34](#).

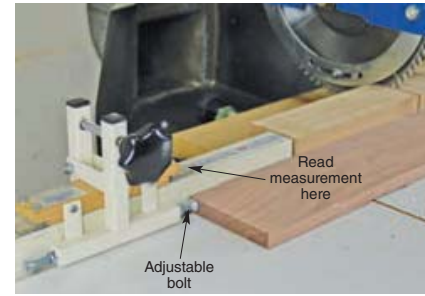

Patrick A. Molzahn

**Figure 23-33.** The stop positions stock for sawing multiple parts to length. The stop is calibrated by adjusting the bolt, and can be used to the left or right of the blade.

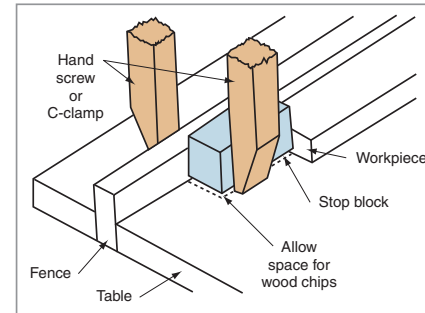

Goodheart-Willcox Publisher

**Figure 23-34.** If a stop is not available, clamp a block of wood to the fence. Raise it slightly to allow dust and chips to pass under.

#### Crosscutting Extra Wide Material

Material widths up to twice the saw's travel distance can be cut. Attach a stop to the fence at the desired length. Support the panel if it might tip. Cut across the material as far as possible. Return the blade to its column position. Turn the workpiece over and finish the cut. Saws with 24" (610 mm) travel will cut 48" (1220 mm) wide sheet material in two passes.

#### Mitering

Make miter cuts by rotating the saw arm to the right or left. See [Figure 23-35](#). Most saws pivot to 45° both ways. Right-hand miters (arm angled to right) are preferred. The motor does not obstruct your



Patrick A. Molzahn

**Figure 23-35.** Compound mitering with the radial arm saw.

view of the cut. Install crosscut blades for miters. Cut a test board first to make adjustments to measurements and stops.

#### Safety Note

Use caution when cutting warped boards on a radial arm saw. Crook should be placed with the convex edge toward the fence. Bowed boards should be placed on the table with the concave side facing up. See [Figure 23-36](#).

#### Kerfing

By raising the blade above the table approximately 1/16" to 1/8" (1.5 mm to 3 mm), stock can be kerfed for radius work. A series of grooves are cut in close proximity to each other through solid stock or panel material, making the material flexible and able to bend to a tight radius. See [Figure 23-37](#).

#### Beveling

The radial arm saw motor and blade assembly tilts 45° left and right for beveling. See [Figure 23-38](#). Select the proper blade for the operation you intend to perform.

#### Protecting the Table

Each different saw setting makes another kerf mark in the saw table. This is because the saw blade must be positioned at least 1/16" (2 mm) below the table surface for through cuts. Over time, the kerfs resulting from different settings make the table rough. Resurface the table by

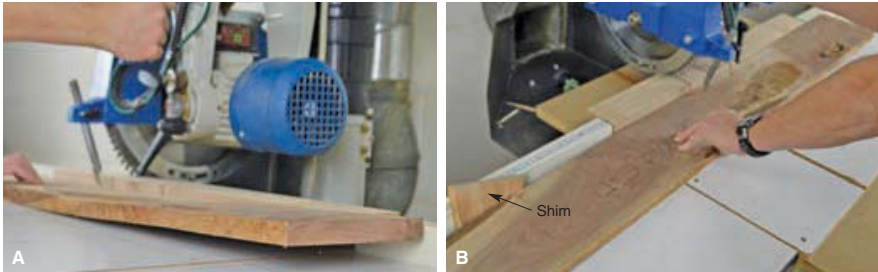

Patrick A. Molzahn

**Figure 23-36.** Warped stock can present problems when cutting on a radial arm saw. A—Position bowed stock with the bow up to prevent pinching the blade. B—Stock with crook can be shimmed with a block of wood if necessary so the stock does not shift when cut.

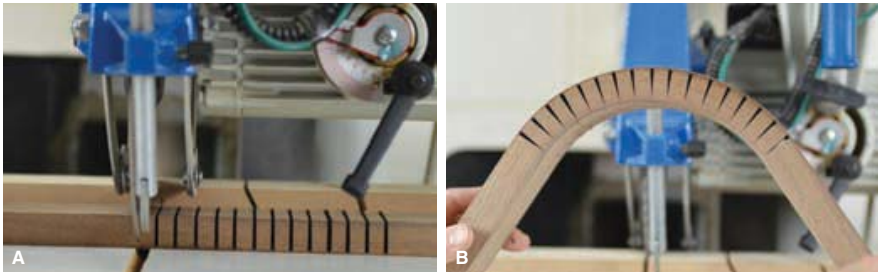

Patrick A. Molzahn

**Figure 23-37.** By raising the saw above the table, boards can be kerfed on a radial arm saw. A—Repeat cuts are made at the same distance between each cut, leaving approximately 1/16" (1.6 mm) of material. B—Kerfed parts can be bent to tight radii.

placing a piece of 1/4" (6 mm) hardboard on it. Screw or nail the hardboard to the saw table, away from the blade's travel.

After replacing a damaged table protector or fence, you must recut saw kerfs. This must be done through the fence and across the table for crosscutting. Later, kerfs may be needed for miter and bevel settings.

## 23.7 Sawing Curved Lines

Stationary machines that cut curved parts include the band saw and scroll saw. Both machines have narrow blades that allow the saws to cut curves. See **Figure 23-39**. Choose a band saw for cutting large radius curves and large cabinet components. A scroll saw, with its smaller blade, is best for small radii and intricate curves.



Patrick A. Molzahn

**Figure 23-38.** Beveling with a radial arm saw.

### Procedure

#### Recutting Saw Kerfs

- The procedure is as follows:
1. With the switch off, disconnect power to the saw.
  2. Raise the blade above the table's surface.
  3. Position the motor-blade assembly over the center of the table for the crosscut, miter, or bevel setting.
  4. Tighten the rip and yoke locks.
  5. Lower the blade until it touches the table protector. Then raise it 1/16" (1.5 mm). Note how far you turn the lever while raising the blade.
  6. Tighten arm adjustments.
  7. Connect power and start the saw. Allow it to reach full speed.
  8. Lower the blade twice as far as you raised it. The cut will be 1/16" (1.5 mm) into the table protector.
  9. Hold the handle securely and loosen the rip lock.
  10. With a tight grip on the handle, push the blade slowly toward the column and cut through the fence. The machine is now ready for use.

### Safety in Action

#### Using the Radial Arm Saw

- Wear eye protection.
- Remove jewelry; secure long hair and loose clothing.
- Hold stock firmly on the table and against the fence for all crosscutting operations. Support long boards and wide panels.
- Be certain that all clamps and locking devices are tight and the depth of cut is correct before starting the motor.
- Always return the saw to the rear of the table after completing a crosscut or miter cut. Do not remove stock from the table until the saw has returned and the blade has stopped.
- Always keep your hands 3" to 4" (76 mm to 100 mm) from the blade.
- Shut off the motor, wait for the blade to stop, and disconnect power before making any adjustments.
- Clean the table of scraps or sawdust before and after using the machine.

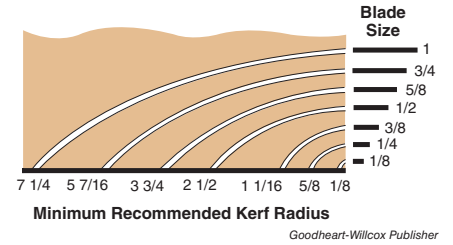

**Figure 23-39.** There is a minimum cutting radius for each band or scroll saw blade width.

## 23.7.1 Relief Cuts

*Relief cuts* allow waste material to break loose as you saw the workpiece. Each cut is made through excess material almost to the cutting line. See **Figure 23-40**. Both band saw and scroll saw operations require relief cuts for making curves when:

- There is a sharp inside or outside curve.
- The curve changes direction: left to right or right to left.
- Cabinet parts will be cut from large pieces of stock. The excess material may be difficult to control. Make relief cuts at least every 4" to 6" (100 mm to 150 mm).

When excess material is removed with relief cuts, there is less chance the blade will twist or break. With relief cuts, you do not need to pull the workpiece back through a long, irregular kerf.

## 23.8 Band Saw

A *band saw* is a very versatile machine. See **Figure 23-41**. Besides making irregular curves and arcs, it can rip, bevel, and resaw. Install a rip fence or use a miter gauge for these operations. With the appropriate jig, the band saw can cut complete circles.

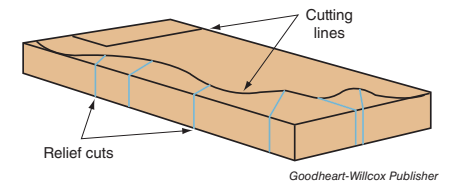

Goodheart-Willcox Publisher

**Figure 23-40.** Relief cuts are made to irregular curves.





Delta International Machinery Corp.

Figure 23-41. Features of the band saw.

The band saw consists of a continuous, thin steel blade that travels on two wheels. The blade is exposed where it passes through the table, or point of operation. The table tilts for beveling. *Blade guides* position and control the blade above and below the table. The upper set of guides is on the guidepost above your work. The *guidepost* is mounted to the upper frame and typically includes a shroud to reduce the exposure to the blade. The post adjusts for different material thicknesses, is set 1/4" (6 mm) above the material, and held by a lock knob.

Most band saws have two wheels. The bottom wheel drives the blade. The top wheel turns freely and can be adjusted to control blade tension and alignment. Proper tension ensures the blade does not stray from the line of cut. With correct alignment, the blade tracks in the center of the wheels. The wheels have rubber tires to prevent damage to the blade's teeth.

The throat is the distance from the blade to the side frame. Refer again to Figure 23-41. This depth determines the widest cut that can be made. The throat depth is usually determined by the diameter of the wheels. See Figure 23-42A. There are band saws that have three wheels. They offer a large throat depth, but use smaller wheels. These machines are noted by their frame shape.

### 23.8.1 Selecting and Installing Blades

Review your project plans when selecting blades. Knowing the material and radii of curves to be sawn helps you choose the proper blade. Select blades according to width, length, tooth shape, blade set, teeth per inch (TPI), and blade gauge (thickness). These terms are discussed later in the chapter.

### 23.8.2 Band Saw Operation

Always plan your sawing sequence before starting the band saw. Short cuts and relief cuts should be made first. Then determine whether the

workpiece will be to the right or left of the saw blade. Saw on the waste side of the cutting line to allow for sanding.

Before making the cut, check your setup. Were all adjustments made? Is the guard within 1/4" (6 mm) of the workpiece? Are all locking devices secured? How will you control your workpiece and waste before and after the cut? Are you standing comfortably in place? Is there a brake within reach to stop the machine from coasting after it is turned off?

Large components are often difficult to cut. See Figure 23-45. The stock can strike the machine frame as you move the workpiece from side to side to follow the curve. If the frame interferes, slowly withdraw the material through the kerf. Be careful not

#### Procedure

##### Changing Saw Blades

The procedure for changing blades is as follows:

1. With the switch off, disconnect power and lock out the machine.
2. Remove the table insert. Back off the blade guides and thrust bearing above and below the table.
3. Remove or swing aside the upper and lower wheel guards. See Figure 23-42A.
4. Release the blade tension by turning the tension control knob. See Figure 23-42B.
5. Remove the old blade from the wheels and guides, and then slip it through the slot in the table.
6. Uncoil the replacement blade and install it on the machine. Be sure the teeth are facing the front of the machine and pointed downward toward the table.
7. Slide the replacement blade through the table slot, between the guides, and onto the wheels.
8. Reset the blade tension. Most machines have a scale to show the correct tension for various blade widths. See Figure 23-42C.
9. Turn the upper wheel by hand, three or four turns, to ensure that the blade is tracking in the center of the wheels.
10. Replace the wheel guards and throat plate.
11. Reconnect power to the machine.
12. Start the machine. Allow it to reach full speed, and then turn it off. Stop the machine with the foot brake if there is one.
13. Check that the blade location is correct for the saw being used. Refer to the operating instructions. If not, adjust the tracking control knob that tilts the upper wheel slightly to bring the blade back into alignment. See Figure 23-43. When you are confident the blade is tracking properly, let the machine run 30 to 60 seconds so it can find its final resting place.
14. Adjust the blade guides. Figure 23-44. The front edge of the side guides should be even with or slightly in back of the tooth gullets. They should never touch the teeth. The rear guide (thrust bearing) should be 0.004" (0.1 mm) away from the blade.

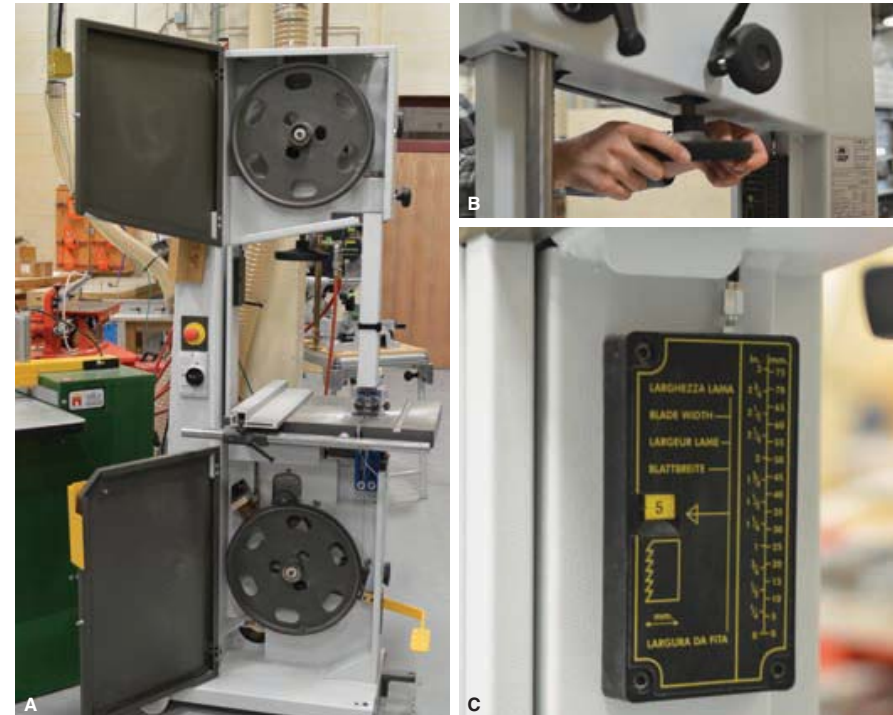

Patrick A. Molzahn

Figure 23-42. A—Remove or swing aside guards to gain access to the blade. B—Loosening blade tension. C—Many saws have a blade-tensioning scale.

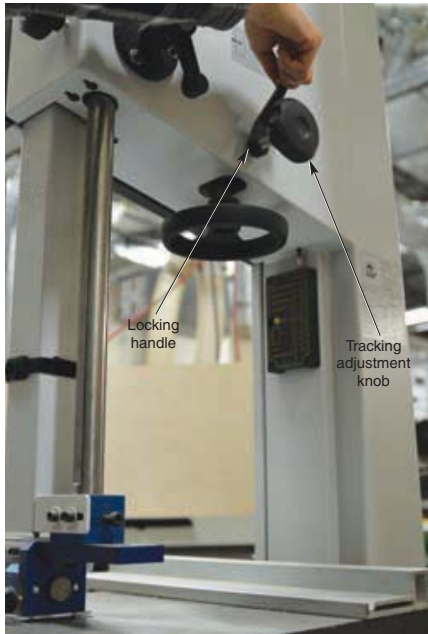

Patrick A. Molzahn

**Figure 23-43.** Tracking adjustment is found on the back of the machine behind the upper wheel. It is usually equipped with a locking handle or wing nut.



Patrick A. Molzahn

**Figure 23-44.** Side guides, behind the saw teeth, keep the blade from twisting or turning. Use a piece of paper to set them approximately 0.004" (0.1 mm) from the side of the blade. The thrust bearing is set 0.004" (0.1 mm) behind the blade. Guides are located above and below the table.

to pull the blade forward from between the blade guides. This could cause the blade to bind, come off the wheels, and even break. More waste material may need to be cut off to feed the workpiece without hitting the frame. If the workpiece is too large for the band saw, use a saber saw.

### Curved-Line Sawing

The primary purpose of a band saw is to cut curved parts. The cutting radius depends on blade width and set. Refer again to **Figure 23-39**. Also, make relief cuts where the curve changes direction. See **Figure 23-46**.



Patrick A. Molzahn

**Figure 23-45.** With large, curved workpieces, first cut away as much waste as possible to prevent it from hitting the machine frame.



Patrick A. Molzahn

**Figure 23-46.** Guide the workpiece with both hands when sawing curves.

When changing direction during a cut, do not push the workpiece against the side of the blade. Anticipate turning your work before you need to change the curve direction.

### Straight-Line Sawing

Ripping and crosscutting a straight line requires a way to guide your work. Attach a rip fence or clamp a straightedge to the table to rip stock. You will need to adjust the fence for blade drift. Drift simply means that the blade is not cutting parallel to the edge of the table. This is caused by several factors including blade sharpness, tension, density of material being cut, and blade tracking. To adjust for drift, begin cutting your stock without a fence. After several inches, stop the cut, holding the stock in place while shutting off the machine. When the blade comes to a complete stop, adjust the fence in line with the stock. See **Figure 23-47A**.

If your saw has a miter slot, use a miter gauge for cross cuts. See **Figure 23-47B**. To saw multiple parts to length, attach a miter gauge stop rod or clamp a stop block near the front of the table as you would with a table saw.

### Ripping Narrow Strips

Narrow strips, 1/8" to 1/2" (3 mm to 13 mm) wide, are often ripped for laminated wood products or inlaying. Measure the desired dimension from the fence to the blade. It is safer to cut strips with the band saw than with the table or other saw. There will also be less waste because the kerf is narrower.



A



B

**Figure 23-47.** Accessories are needed to saw straight lines. A—Rip fence. B—Miter gauge.

Joint the edge before cutting. With a sharp blade and well-tuned saw, the cut edge should be smooth enough for gluing.

### U-Shaped Cutting

In a *U-shaped cut*, three sides of an opening are sawn. The edges of the cutout may be straight or curved. There may not be enough room for relief cuts. Several alternatives include:

- Saw straight into the cutout on each side. Withdraw the workpiece carefully after each pass. Then cut a curve as small as your blade size allows. Complete the cutout by sawing away any remaining waste. See **Figure 23-48A**.
- Drill two turn-around holes. These provide room in the corners for you to change the workpiece direction without twisting the blade. Clean up the corners with an extra cut or a file. See **Figure 23-48B**.
- If the inside corners of the pocket are curved as part of the design, bore the holes with the proper radius bit. Then saw the waste material away. See **Figure 23-48C**.

### Beveling

Most band saw tables or heads tilt for bevel sawing. For tilting tables, loosen the table tilt lock knob and adjust the angle according to the tilt scale. See **Figure 23-49**. If there is no tilt scale, set the angle with a T-bevel. For a band saw with a tilting head, loosen the bevel lock knob, turn the handwheel, and adjust

Patrick A. Molzahn



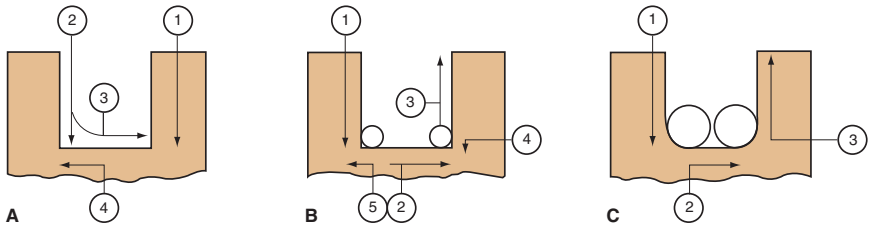

Goodheart-Willcox Publisher

**Figure 23-48.** Series of drilled holes and kerfs for cutting U-shaped cutouts. The numbers indicate the recommended cutting sequence.



Patrick A. Molzahn

**Figure 23-49.** Adjust the table angle by loosening the trunnion knobs and using the tilt scale or a bevel to set the angle.

the tilt angle to the bevel scale. See **Figure 23-50**. The scale may not be accurate, so verify the angle with a T-bevel before proceeding.

Straight bevels can be ripped freehand or with a fence or miter gauge. Feed workpieces for curved cuts as you would if the table was flat. See **Figure 23-50B**. Once you begin the cut, continue in one direction only. Otherwise you will cut a reverse bevel. Remember, the kerf made on the other face differs from the cutting line you follow.

### Sawing Multiple Parts to Size

Multiple parts can be cut to size in a single operation. Stack and fasten workpieces together with nails located away from the cutting line. See **Figure 23-51**. Make relief cuts on each side of the nails and elsewhere as needed. Saw along the



Chuck Davis Cabinets; Patrick A. Molzahn

**Figure 23-50.** Beveling on the band saw. A—A tilting head and a miter gauge is used to produce a compound bevel. B—A tilting table with or without a fence may be used for straight bevel.

cutting line. The last two cuts should be those that free the parts from the nailed-together waste.

In addition, you can hold workpieces together with two-sided tape. This prevents potential blade damage caused by sawing through nails. However, tape may not hold if the stock is warped.

For sawing duplicate workpieces with parallel edges, such as chair rails, attach a round fence. See **Figure 23-52**. Saw the first workpiece to establish the shape. Then secure the fence to the table a given distance from the blade. Hold the material against the fence as you feed through the cut.

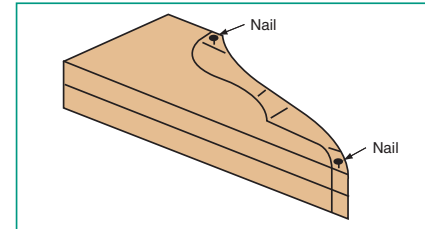

Goodheart-Willcox Publisher

**Figure 23-51.** Stack material when sawing duplicate workpieces.

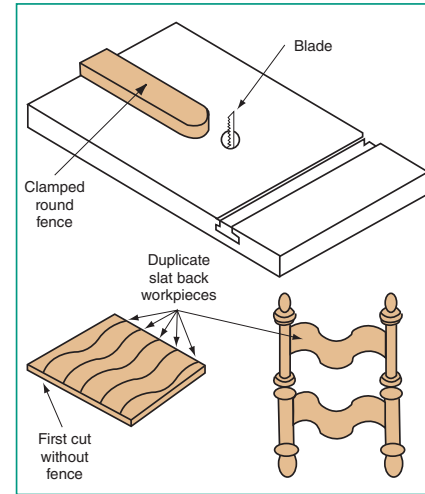

Goodheart-Willcox Publisher

**Figure 23-52.** A round fence helps saw duplicate workpieces that have gentle curves.

Patterns can be used with a round fence if the curves are not too tight. The round fence is moved to the blade, which sits in a pocket at the tip of the fence. A pattern is attached to the stock. The pattern rides against the fence, creating an exact duplicate of the part desired.

### Resawing

Resawing using a table saw was discussed earlier. Another method is to use a band saw and an auxiliary fence or a pivot block. The width of material that can be resawn depends on how high the upper guidepost rises. The blade has more of a tendency to wander when the guidepost is raised high.

Resawing on the band saw is a one-pass process, **Figure 23-53**. An auxiliary fence can be used or a pivot block can be clamped away from the blade at a distance equal to the desired material thickness. Mark the resaw line on the material. If using a straight fence, you will have to adjust for drift, as explained earlier. Pivot blocks are quicker to set up, but a straight fence

### Safety in Action

#### Using the Band Saw

- Fasten loose clothing, secure long hair, and remove jewelry.
- Always wear eye protection.
- If you hear a rhythmic click as the wood is being cut, the blade may be cracked. Stop and inspect the machine.
- If the blade breaks, shut off the machine and disconnect the power. Lock out the machine before removing the broken blade.
- When installing a new blade, make sure the teeth are pointing down, toward the table.
- Make sure the blade is properly tensioned.
- Lock the upper guide no more than 1/4" (6 mm) above the workpiece.
- Hold the stock firmly on the table as you cut.
- Maintain your balance as you cut.
- Make relief cuts as necessary.
- Keep your fingers away from the point of operation while the blade is moving.
- Do not cut a small radius with a wide blade, without first making relief cuts.
- Minimize backing out of a kerf. This could pull the blade off the wheels.



Patrick A. Molzahn

**Figure 23-53.** Resawing on the band saw is a one-pass operation. A—Holding the material firmly against an auxiliary straight fence. B—Holding the material against a rounded pivot block for support.

is faster when resawing multiple pieces. Use a push stick as you near the last 3" (76 mm) of the workpiece. Make sure the stock is supported behind the blade.

## 23.9 Scroll Saw

The *scroll saw* cuts small radius curves. Its thin, narrow blade saws intricate work, such as marquetry and inlay. A scroll saw operates much like the band saw. However, unlike a band saw, the scroll saw will cut out pockets (interior openings).

### 23.9.1 Scroll Saw Parts

Scroll saw parts include a table, hold-down, blade clamps, blower nozzle, and a guard. See **Figure 23-54**. The table tilts to make bevel cuts. A hold-down keeps material from vibrating on the table. It is attached to the machine frame or to a guidepost. The blade, held by two clamps, cuts by moving up and down. The lower chuck drives the reciprocal motion of the blade. The upper chuck is spring-loaded and retains blade tension. A blower nozzle is attached to an air supply line. It blows away chips so the cutting line remains visible.

The majority of scroll saws are rear-tension saws. With rear-tension scroll saws, the entire overarm pivots as the blade moves up and down. Blade tension is adjusted at the rear of the machine. The advantage of rear-tension saws is that the blade moves slightly back from the workpiece. This helps prevent the workpiece from jumping up and down. The hold-down serves as a guard for rear tension scroll saws.

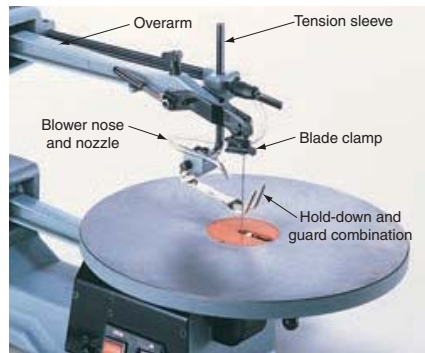

Delta International Machinery Corp.

**Figure 23-54.** Features of a scroll saw.

Scroll saw size is based on the distance from the blade to the back of the overarm. This is called the throat depth and may vary from 12" to 24" (305 mm to 610 mm). The throat depth limits the length of material that can be cut.

### 23.9.2 Selecting and Installing Scroll Saw Blades

Blades for scroll saws are very narrow and so are capable of sawing a small radius. The number of TPI varies. A rule of thumb is to select blades that will have three or more teeth in contact with the wood at all times. This way, the edge next to the kerf will not splinter as much.

- **Variable.** A variable speed scroll saw adjusts while the machine is running.
- **Pulleys.** A belt is tracked over opposing step pulleys. Make sure that the switch is off and power is disconnected while you move the belt.

### 23.9.4 Scroll Saw Operation

There are two types of cuts made with the scroll saw. One is around or through the workpiece, typically called an *outside cut*. The other is an *interior cut* for pocket cutouts. An example of a pocket cutout would be a hole cut out of the center of an object.

#### Procedure

##### Changing a Scroll Saw Blade

The procedure to change a blade is as follows:

1. With the machine off, disconnect power and lock out the saw.
2. Remove the table insert (if equipped) and loosen the blade tension.
3. Move the lower blade clamp to the top of its stroke by turning the motor shaft knob.
4. Loosen the thumb screws or set screws on upper and lower blade clamps.
5. Remove the old blade.
6. Slip the replacement blade into the lower blade clamp. Point the teeth downward and toward the front of the machine.
7. Tighten the lower blade clamp to secure the blade.
8. Pull the upper blade clamp down, insert the blade, and tighten the screw.
9. Tension the blade and install the table insert (if equipped).

#### Procedure

##### Making Outside Cuts

The procedure for outside cuts is very similar to the procedure used on the band saw. For outside cuts, proceed as follows:

1. Plan your sequence for making relief cuts. Even though the scroll saw has a narrow blade, relief cuts may help when cutting small radius curves.
2. On tension sleeve scroll saws, lower the hold-down until it rests on the material. Press lightly on the blade guard, and then tighten the guidepost. The hold-down on some rear-tension saws adjusts automatically to the workpiece thickness.
3. Aim the air nozzle at the point of operation.
4. Adjust the blade speed if necessary. Saw thick and hard materials at slow speeds. Faster speeds and fine tooth blades are appropriate for thinner materials.
5. Fine tooth blades leave smooth cut edges.
6. Start the machine and proceed with your cutting sequence. Relief cuts prevent having to back the blade out of a long saw kerf.

### 23.9.3 Scroll Saw Setup

Preparing to use the scroll saw requires just a few simple steps. For saws having a guidepost, raise or lower the post so material can pass under the hold-down. The scroll saw may have one of three speed adjustments.

- **Electronic.** A speed knob adjusts the speed, which is displayed in a digital readout.

#### Beveling

Beveling on the scroll saw is done much like the band saw operation. Tilt the table, and then adjust the hold-down to the tilt angle, **Figure 23-55**. Keep the workpiece on the same side of the blade until the cut is complete.



### Pocket Cuts

The scroll saw is the only stationary saw capable of cutting pockets with ease. Since the blade is not a continuous loop, it can be threaded through a hole in the workpiece. See [Figure 23-56](#).

#### Procedure

#### Making Pocket Cuts

After you drill holes in the waste section, proceed as follows:

1. With the machine off, disconnect the power to the saw.
2. Raise the chuck to the top of the stroke by turning the motor shaft.
3. With the tension released, loosen the upper chuck clamp to free the blade.
4. Bend the blade slightly to slide it through the hole drilled in your workpiece.
5. Place the material on the table and rechunk the blade.
6. Re-tension the blade and make sure the hold-down presses lightly on the material.
7. Holding the material down with one hand, press the *start* button.
8. Continue with the inside cut. If there are sharp curves and inside corners, relief cuts may be needed. See [Figure 23-57](#).
9. When finished with the cutout, stop the machine, disconnect power, and loosen the top blade clamp to free the blade. Repeat the procedure for additional cutouts.



Patrick A. Molzahn

**Figure 23-55.** Some scroll saws feature tilting tables.

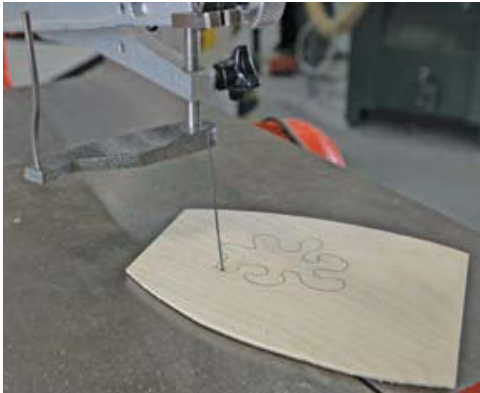

Patrick A. Molzahn

**Figure 23-56.** When cutting interior curves, free the top end of the blade and thread it through a predrilled hole.



Patrick A. Molzahn

**Figure 23-57.** Completing an interior cut. A—Drill a hole close to the outer boundary. B—The completed cutout.

#### Safety in Action

##### Using the Scroll Saw

- Fasten loose clothing, secure long hair, and remove jewelry.
- Wear safety glasses, goggles, or a face shield.
- Make sure the saw blade teeth point down.
- Make sure the proper blade type and size is installed.
- Keep the floor around work area clean and free from sawdust and scraps.
- Change blades (and speed on machines having step pulleys) with switch off and the power disconnected.
- Check all adjustments by rotating the motor by hand before turning power on.
- The hold-down should press lightly on the material being cut.
- Stop the machine before removing excess stock from the table.
- Do not attempt to saw large stock without proper support.
- Hold material firmly and feed it into the blade at a moderate speed.
- Make relief cuts before cutting tight curves.
- Shut off the power and let the machine come to a complete stop before leaving it.

## 23.10 Selecting Blades

Blades, regardless of the machine they are on, are designed to cut efficiently and effectively. Selecting the proper blade is an important part of sawing. Using the wrong blade may ruin the workpiece, dull the blade prematurely, or result in extra work, such as sanding. For example, crosscutting with a rip blade creates problems. Rip teeth are larger and have a different cutting angle that may cause the wood to splinter.

The blade you choose depends on the sawing operation. You may be sawing solid wood or plywood across or along the grain. You could also be cutting nongrain composites such as hardboard, particleboard, or even plastic.

After making a cut, inspect the cut edges of the workpiece. Look to see how rough or smooth they are. Burn marks result from using a dull blade,

improperly adjusting the rip fence, or feeding stock too slowly. Inspect the blade frequently to determine how well it is performing.

Saw blade performance is based on tooth design and chip load. **Chip load** is the thickness of a chip that is removed by one cutting edge of the tool. In the case of a saw blade, chip load depends on the:

- Number of teeth.
- Size of the gullet.
- Speed of the blade.
- Rate of feed.

Chip load is a factor for all types and styles of blades. If wood chips totally fill the gullet, the blade will cut poorly. This is because there is no more room in the blade to hold sawn chips. You can feed faster with large gullet blades, but the sawn edge will be rougher. Too much pressure when feeding causes the blade to heat up due to increased friction. Excess heat can remove the temper from a blade, causing it to dull prematurely.

### 23.10.1 Circular Blade

Circular blades are used on table saws, radial arm saws, power miter saws, and various stationary power saws. Important blade specifications include blade diameter, tooth design (hook angle, cutting edge shape, and number of teeth), kerf width, and the size of the arbor hole.

#### Diameter

Machines are made to use blades with a wide range of diameters. Machines are described in terms of the maximum blade diameter installed in the machine, such as a 10" table saw or a 7 1/4" portable circular saw. Smaller diameter blades reduce the maximum depth of cut. Most 10" (254 mm) blades mounted on a 10" table saw will cut through 2" (50 mm) material at 45° and 3" (75 mm) material at 90°.

#### Hook Angle

**Hook angle** refers to the angle at which the front edge of the tooth contacts the material. This angle is created between the face of the tooth and a line that extends from the tooth tip to the arbor hole. Rip blades may have a hook angle between 10° and 20°. Blades designed for power miter, radial arm, and other pendulum type saws generally have smaller hook angles and may even have 0° or a negative hook angle. A negative angle gives you greater control over the feed rate.

### Cutting Edge

There are various standard blade cutting edges. The cutting edges are determined by the tooth shape. The type of material and grain direction through which a blade will cut is based on the tooth shape. Teeth may be flat-top (square), bevel shaped, or a combination of the two shapes. Some combination blades may have teeth shaped several ways. For example, one tooth is square followed by several that are beveled.

The cutting edge of carbide tips are ground to various shapes, commonly referred to as *grinds*, **Figure 23-58**. The most popular grinds and uses are as follows:

- **Flat-top (FT) grind.** The blade has larger gullets, fewer teeth, and will accept greater chip loads for higher feed rates. See **Figure 23-58A**. Excellent for ripping solid wood when speed is more important than cut quality.

- **Alternate top bevel (ATB) grind.** Top bevel shaped teeth sever the material with a shearing action, alternating left and right. See **Figure 23-58B**. This grind is used for crosscutting or a combination of crosscuts and rip cuts. Blades of this design with a high number of teeth will produce a higher quality of finish cut in wood. Blades with a high bevel angle (30°) are able to produce superior cuts on both sides of thermofused melamine and HPDL panels. Use blades with a negative hook angle for improved control over feed rate.
- **Alternate top bevel with raker grind.** Two sets of alternate left and right top bevel teeth are followed by a raking action flat-top tooth with large round gullet to ease chip removal. See **Figure 23-58C**. This is an excellent choice for a combination blade.
- **Triple-chip (TC).** Triple-chip teeth are beveled on both sides with a small flat on the top edge. Some blades alternate triple-edge teeth with flat-top teeth for dual-action cutting. See **Figure 23-58D**. The triple-chip teeth remove material from the center of the kerf, followed by the flat-top raker to clean out remaining material from both sides. Excellent results can be achieved on plywood and plastics. They are often used on power miter and radial arm saws. Triple-chip blades with a negative hook angle are preferred for cutting nonferrous metal.

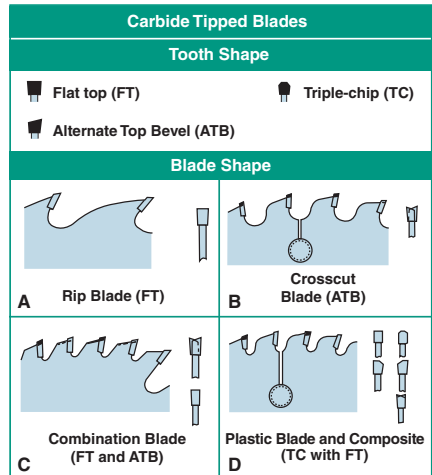

Goodheart-Willcox Publisher

**Figure 23-58.** Four popular tooth designs. A—Flat-top grind (FT). For cutting material with the grain. B—Alternate top bevel grind (ATB). For across-the-grain cutting. Higher quality of cut comes from blades with the highest number of teeth. C—Alternate top bevel with raker (ATB and R). Excellent for a combination of crosscutting and rip cutting. D—Triple-chip and flat grind (TC with FT). Primarily for use with composite products and plastics. Blades with a negative hook angle are recommended for cutting nonferrous metals and for use on radial arm saws.

### Arbor Hole

The size of the arbor hole is generally larger on blades with a larger diameter. Commonly referred to as the bore, blades up to 10" (254 mm) in diameter have a 5/8" (16 mm) bore. Larger blades, such as 12", 14", and 16" (305 mm, 356 mm, and 406 mm), have a 1" (25 mm) bore.

### Other Considerations

Between each tooth is a *gullet*. It is where chips accumulate as teeth cut through the material. The chips absorb heat from the blade and are then thrown out when the tooth exits the stock.

Circular blades are either flat, hollow ground, or thin rim. See **Figure 23-59**. Flat blades are set to create a wider saw kerf. The teeth are larger than the blade to create a kerf slightly wider than the steel plate. The kerf prevents the blade body from binding. A hollow ground blade leaves a smoother cut edge on the workpiece. The thinner cross section of the blade reduces binding. However, binding and heating will occur if the blade is not raised at least 1" (25 mm) above the stock. A thin rim (thin kerf) blade creates the narrowest kerf and thus, conserves material. However, heat buildup is a problem with thicker material.

Most blades are designed with expansion slots in the blade. A warm blade will warp and affect the smoothness and width of the kerf. On carbide blades over 12" (254 mm) in diameter, holes at the bottom of the expansion slots are sometimes fitted with aluminum plugs. These help reduce noise and vibration, resulting in a smoother cut.

## 23.10.2 Band Saw Blades

A band saw blade is an endless bonded loop of thin narrow steel with teeth on one edge. Select band saw blades according to various specifications. The

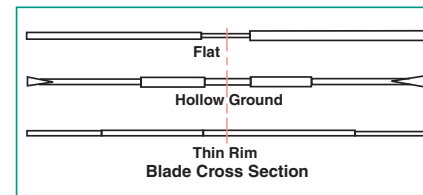

Goodheart-Willcox Publisher

**Figure 23-59.** Circular blades are either flat, hollow ground, or thin rim.



Patrick A. Molzahn

**Figure 23-60.** Expansion slots are cut into the blade to prevent warping as the blade heats up during use. Coatings can also reduce heat buildup by reducing friction.

length of the loop is critical. While it is possible to buy 100'–500' (30.5 m–152 m) coils and cut and weld together your own blades, most users buy blades sized for their machine. Your machine manual will specify the correct length needed.

Blade width is important. It may vary from 1/8" to 1" (3 mm to 25 mm) or wider. Blades 1/8"–1/2" (3 mm–13 mm) are used most often for sawing curves. Wider blades are more appropriate for resawing.

Blades vary in hardness. Some inexpensive blades are made of untempered steel. Others may have a flame-hardened cutting edge and possibly a hard-tempered back.

There are several alternative tooth shapes and blade sets available. See **Figure 23-61**. A regular blade has a 0° hook angle and a straight front and back on each tooth. A hook-tooth blade has about a 10° positive hook angle. A skip-tooth blade has a straight tooth front, 0° hook, and a long gullet. Regular and hook-tooth blades have teeth set alternately left and right. Skip-tooth blades may have a raker tooth set. A third set-type is the wavy tooth blade. Several teeth are set right and then left. They are separated by a raker tooth. A regular blade works best for wood only. The hook-tooth cuts well on most wood, fiberglass, and plastic laminate. The skip-tooth blade is better for soft woods and plastics. These materials tend to overload and clog other blades' gullets.

Blades with carbide teeth are also available. They offer more precise cuts, increased wear resistance, and the ability to cut composite materials. Although expensive initially, carbide will outlast carbon steel blades by as much as 25 to 1, and they can be resharpened.



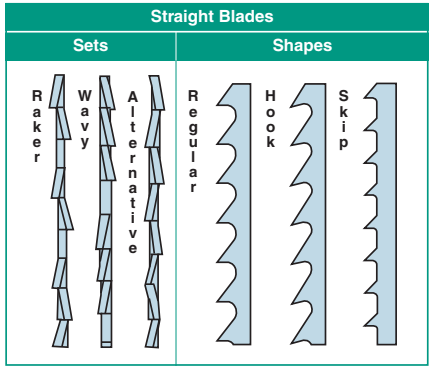

Figure 23-61. Band saw blades shapes and sets.

### 23.10.3 Scroll Saw Blades

The scroll saw also uses several different blade types. See Figure 23-62. Standard blades cut in only one direction. They vary in width and number of TPI. Common widths are 1/8"–1/4" (3 mm–6 mm).

Scroll saw blades typically have 7 to 20 TPI. They have beveled teeth that are alternately set. Normally, at least three teeth should contact the material at all times. A 7 TPI blade would be best for soft lumber with high moisture content. A 20 TPI blade, about 1/32" (1 mm) wide, is proper for veneer and other very thin material. The standard blade length is 5" (127 mm). In addition, a round blade with spiral teeth is available. You can move the material in any direction while cutting.

Flat, abrasive-coated blades, 1/4" (6 mm) in width, are available for sanding inside corners.

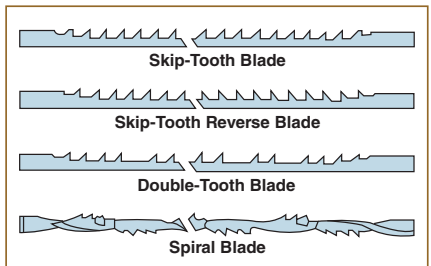

Figure 23-62. Scroll saw blades.

## 23.11 Maintaining Saw Blades

Saw blades should be sharp, free of rust or resin, and with all teeth intact. Inspect blades frequently for cracks (especially in the gullets), warp, bluish color (sign of overheating), and missing or damaged carbide teeth. Proper maintenance may include cleaning and sharpening or discarding.

Clean blades with a solvent such as paint thinner. Oven cleaner may be used on more stubborn resins. Wear rubber gloves to protect your hands. Rust can be removed with oil and fine steel wool. Remove the oil and coat the blade with paste wax or silicone spray before storing it.

Carbide-tipped blades cannot be hand sharpened. Machine grinding with a diamond wheel is the only method to sharpen a carbide-tipped blade and is best left to a professional.

## 23.12 Maintaining Power Saws

Maintaining stationary power saws properly will increase their usable life. Inspect, clean, adjust, and lubricate saws periodically. The machine must be disconnected from electrical power and locked out before servicing. For complex repairs, refer to the owner's manual.

### 23.12.1 Table Saw

Table saws should accurately cut material. If you check a workpiece and find it out of square that could indicate a table, miter gauge, or fence problem.

Imagine you are sawing using the miter gauge. You notice the workpiece pulls away from or feeds in toward the blade. The miter gauge slot may not be parallel to the blade. Check this by comparing readings with a dial indicator, Figure 23-63. The dial should not move as you slide the miter gauge. (Be sure the blade is not warped. Install a new blade or a flat steel plate.) To correct this problem, loosen and turn the tabletop slightly.

Now imagine you are sawing using the rip fence. The workpiece pulls away from or rubs tightly against the fence. This indicates the fence is out of alignment. If the fence was dropped at some point, one or more locking mechanism bolts or nuts may have slipped. Loosen them, move the fence to align it, and then retighten the bolts or nuts.

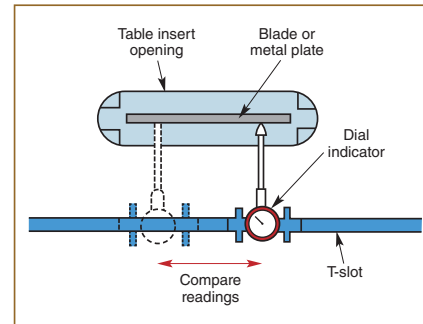

Patrick A. Molzahn; Goodheart-Willcox Publisher

Figure 23-63. Check distance readings from the blade to the table to determine whether the arbor and table are aligned.

Make accurate adjustments with a dial indicator. See Figure 23-64. Without the indicator, make the same comparisons with a wood block. However, this method is less accurate.

At times, handwheels become hard to turn. First, check to see that the lock knobs are loose. If they are, lubricate screw threads with silicone spray or powdered graphite. Sawdust will stick to oil and may create a condition worse than before.

There may be times when you may smell rubber or varnish around a table saw. A rubber scent can occur when the belt is not tracking properly. The belt overheats and may harden. Then it can crack and possibly break. An overheated motor has a definite varnish-like smell. Motors have a built-in fan to keep them cool. It can attract sawdust. Sawdust accumulation can obstruct the airflow and cause the motor to overheat and possibly burn out.

Rust occurs on unpainted steel parts. Remove the rust with oil and steel wool or fine emery

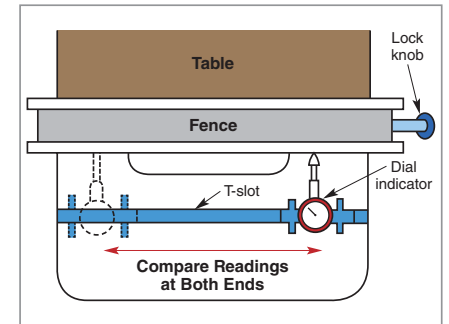

Patrick A. Molzahn; Goodheart-Willcox Publisher

Figure 23-64. With the fence clamped, check the distance from the fence to a table slot at both the front and back.

cloth. Wipe the oil away because it will stain your wood. Then coat the table and other parts with paste wax. Wax is less likely to be absorbed into the wood.

### 23.12.2 Radial Arm Saw

A radial arm saw has many movable parts. Rust, lack of lubrication, and excessive torque on levers are sources of maintenance problems. Check table and fence alignments before making cuts. Do so with a square, protractor, T-bevel, or other device. Machine scales may not be accurate.

The table may have to be leveled so the blade will be square. Do so by removing the table protector and wood top. Adjust the leveling bolts as necessary and reset the locknuts. See Figure 23-65.

Sometimes the saw kerf is not straight. The saw assembly movement bearings inside the overarm could be out of adjustment and allowing side play.

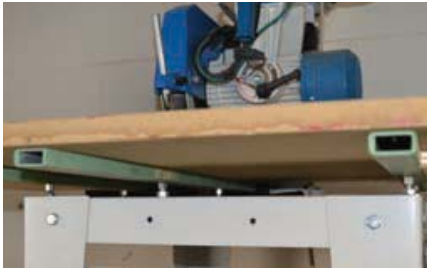

Patrick A. Molzahn

**Figure 23-65.** A radial arm saw table should be flat and level. Remove the table and adjust the bolts under the platform.

Adjustment may or may not be possible. If not, the bearings will need to be replaced.

### 23.12.3 Band Saw

With band saws, you must be able to apply the proper blade tension and adjust the tilt on the upper wheel for tracking. See **Figure 23-66**. You must also be able to align the upper and lower blade guides and set the rear blade guide for different blade widths.

#### Blade Tension

Blade tension is controlled by a tension control knob, **Figure 23-67**. It moves the upper wheel toward

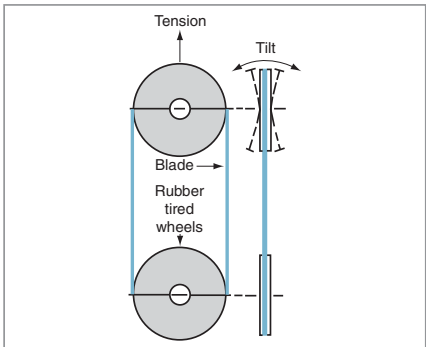

Goodheart-Willcox Publisher

**Figure 23-66.** The upper wheel on a band saw blade raises and lowers for tension adjustment and tilts for tracking adjustment.



Patrick A. Molzahn

**Figure 23-67.** The tension control has a scale to indicate proper tension for various width blades.

or away from the lower wheel. Most machines have a scale and marker to note proper tension for a given blade width. Depending on the age and quality of the tensioning spring, the scale may or may not be accurate. The best way to tension a band saw is to use a tension gauge. If a gauge is not available, try pushing on the side of the blade. It should deflect no more than 1/8"–1/4" (3 mm–6 mm) under moderate pressure.

#### Blade Tracking

The tracking adjustment moves the upper wheel toward or away from the operator. The adjusting mechanism is typically located on the back of the upper wheel housing. See **Figure 23-68**. When a blade is installed with the proper tension, turn the upper wheel slowly. Make sure the blade remains centered on the tire. Turn the wheel at least three or four revolutions. Adjust the tracking knob or screw as necessary. When you are confident that the blade



Patrick A. Molzahn

**Figure 23-68.** Tracking adjustment tilts the top wheel to allow the blade to track.

will not come off the wheel, run the saw for 30–60 seconds to ensure that the blade reaches its final resting position.

#### Side Blade Guides

Guides may be hardened pieces of steel, ceramic, composite material, or ball bearings on each side of the blade. See **Figure 23-69**. Fitting a blade between these guides is critical. Slip a piece of paper or tape between the blade and each side guide. If it moves freely, the guides have proper side clearance.

The teeth on the blade must never touch the hardened guides or bearings. If this happens, the blade loses its set. It may pinch in the kerf, heat up, and burn the material being cut. The guides should be located just behind the blade gullet.

#### Thrust Bearing

The guide behind the blade is called the thrust bearing. A *thrust bearing* is a ball bearing or disk mounted directly behind the blade. It supports the blade while sawing and is part of the blade-guide assembly. There should be a 0.004" (0.1 mm) space

between it and the back of the blade. This adjustment may be made by moving the guide. Like the side guides, use a piece of paper to set the proper distance.

#### Storing a Band Saw Blade

Band saw blades should be coiled for storage. They may be hung or boxed easily when coiled into a loop.

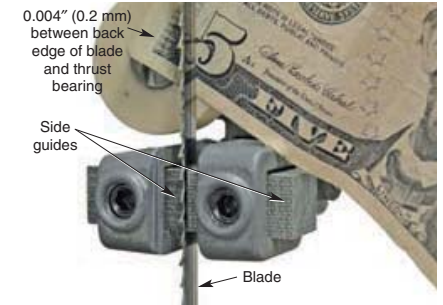

Patrick A. Molzahn

**Figure 23-69.** Use paper when checking spacing between the blade and the side guides and thrust bearing. Paper is approximately 0.004" (0.2 mm).

#### Procedure

##### Coiling a Band Saw Blade

To coil the blade, proceed as follows:

1. Hold the blade vertically in front of you with both hands. One hand is in the center of each side of the loop. Thumbs are up and on the outside of the blade, **Figure 23-70A**.
2. Fingers are curled toward you on the inside gripping the blade.
3. Turn both wrists so you can see your thumbnails, **Figure 23-70B**. The blade begins to twist.
4. While turning, bend your wrists downward. The top of the loop moves away from you and drops toward the floor.
5. Bring your wrists together and cross them without changing your grip.
6. As you cross your wrists push them toward the floor, **Figure 23-70C**.
7. The top of the loop in step 1 will curl back toward you, forming a three-loop coil, **Figure 23-70D**.



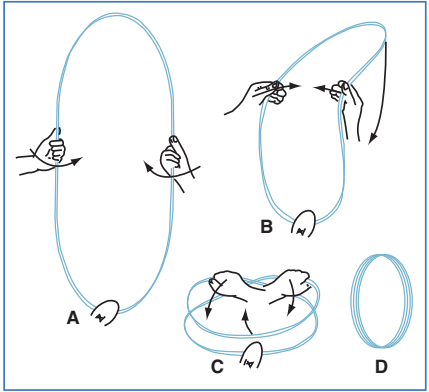

Goodheart-Willcox Publisher

**Figure 23-70.** With practice, you can coil a band saw blade into three equal loops.

### 23.12.4 Scroll Saw

Scroll saws are maintained like other machines. Be sure to:

- Select the proper blade guide for the blade being used. It guides the blade and prevents tooth damage.
- Set the tension sleeve or rear-tension device as described earlier.
- Check the oil level periodically in the housing under the saw table. Oil prevents wear and heat buildup.

- Add a small amount of oil or graphite in the tension sleeve or rocker pins. This will prevent excessive wear.

Some scroll saws have an air pump, hose, and nozzle. This assembly blows off chips to keep the cutting line visible while sawing. Check the airflow periodically because the pump could get damaged or the hose could be loose or broken.

#### Safety in Action

##### Saw Safety Review

Saws are versatile tools that work best when proper attention is paid to safety. In all cases, proper clothing is important. Wear a short sleeved shirt or roll the sleeves above the elbow. Remove rings. Use proper procedures when cutting a dado, **Figure 23-71A**. The operator is using a push stick to control the workpiece and an auxiliary guard is in place. The proper technique for ripping requires keeping hands away from the blade, **Figure 23-71B**. The guard and riving knife are in place. Using proper crosscutting procedure, the operator keeps hands well away from blade, **Figure 23-71C**. The operator uses a miter gauge to push the workpiece, has a guard in place, and stands well away from the path of any flying wood chips.

Follow these and all safety guidelines as you work. Have firm footing and observe minimum distances from the point of operation. Use your sense of sight, sound, touch, and smell to detect potential problems.

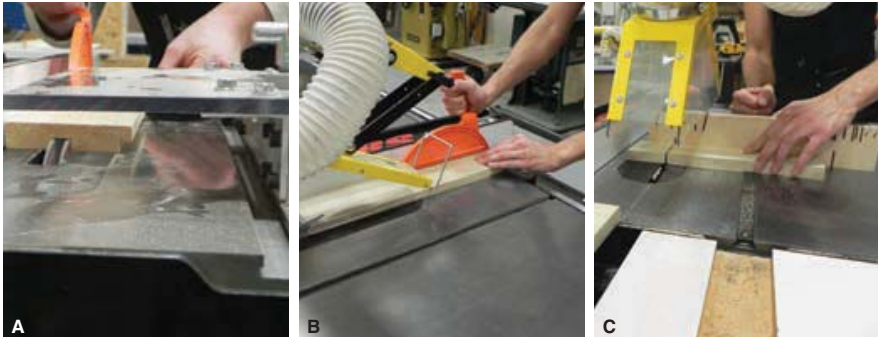

Patrick A. Molzahn

**Figure 23-71.** Safety is your first concern when sawing on stationary power machines.

### Summary

- Sawing is a fundamental process in cabinet-making. Stationary power saws cut wood and composite materials to component sizes.
- Generally speaking, select the proper saw blade for efficient operation. Selecting the wrong blade may result in a splintered surface or burned edge.
- Use saws with circular blades to make accurate straight-line cuts. The diameter of the blade helps keep the cut straight.
- Stationary power saws that use a circular blade include the tilting-arbor table saw, tilting table saw, horizontal and vertical panel saw, beam saw, and radial arm saw.
- The major components of a tilting-arbor table saw are a horizontal table on a machine frame, circular blade that extends up through a table insert, tilting arbor that adjusts the blade angle from 0° to 45°, and a motor.
- Use a rip fence, miter gauge, sliding table, or jigs and accessories to guide material past the blade on a table saw.
- Blade guards keep hands away from the blade and help control sawdust.
- Circular saw blades are categorized by tooth design, kerf width, arbor hole size, and other features.
- Table saw setup includes deciding whether to use the rip fence or miter gauge, setting the blade height, and squaring the blade.
- Table saws can be used for ripping, crosscutting, beveling, mitering, resawing, cutting dados, compound mitering, shaping, tapering, and joint making.
- Use a panel saw to cut full-size sheets. Horizontal and vertical panel saws are available.
- Radial arm saws are used primarily for sawing stock to length. The saw blade, blade guard, and motor are above the table.
- The radial arm saw can be used for crosscutting, mitering, kerfing, and beveling.
- Band saws and scroll saws are used to cut curved parts.
- Relief cuts allow waste material to break loose as a curved workpiece is sawed.

- A band saw consists of a continuous, thin steel blade that travels on two wheels. The blade is exposed where it passes through the table.
- Band saws are used for curved-line sawing, straight-line sawing, ripping narrow strips, U-shaped cutting, beveling, sawing multiple parts to size, and resawing.
- Plan your sawing sequence before starting the band saw. Make short and relief cuts first, determine whether the workpiece will be to the left or right of the blade, and saw on the waste side.
- Scroll saws cut small radius curves. They are used to make outside cuts and interior cuts, and for beveling. Parts include a table, hold-down, blade clamps, blower nozzle, and a guard.
- Generally speaking, select the proper saw blade for efficient operation. Selecting the wrong blade may result in a splintered surface or burned edge.
- Choose a blade based on the sawing operation to be performed.
- Circular blades are used on table saws, radial arm saws, power miter saws, and various stationary power saws.
- A band saw consists of a continuous, thin steel blade with teeth on one edge.
- To saw efficiently, blades must be sharp. Jointing, setting, cleaning, and filing (grinding) are all steps in sharpening.
- Some blades can be hand sharpened. However, it is best to have blades sharpened by a professional with the appropriate tools.
- Maintaining your machinery is important for achieving quality results. Inspect, clean, adjust, and lubricate them periodically.

### Test Your Knowledge

Answer the following questions using the information provided in this chapter.

1. List two stationary saws you might choose for straight-line cuts.
2. True or False? Saws used to cut curves can also cut a straight line, if a straightedge or fence is used.
3. The \_\_\_\_\_ of a circular saw blade helps keep the cut straight.

4. Name four tools that can be used to guide material past the blade on a table saw.
5. What table saw safety feature helps prevent material from being thrown back toward the operator?
6. Name five ways to categorize circular saw blades.
7. Which direction do you turn the table saw arbor nut to loosen it?
8. For cuts other than bevels, the blade must be at \_\_\_\_\_ to the table.
  - A. 20°
  - B. 45°
  - C. 90°
  - D. 180°
9. Cutting wood or plywood along the grain is known as \_\_\_\_\_.
  - A. ripping
  - B. crosscutting
  - C. beveling
  - D. resawing
10. Cutting through wood or plywood across the face grain is known as \_\_\_\_\_.
  - A. ripping
  - B. crosscutting
  - C. beveling
  - D. resawing
11. Name two methods for cutting duplicate workpieces to equal lengths on a table saw.
12. On a tilting-arbor table saw, the \_\_\_\_\_ is tilted for beveling.
13. When is resawing on the table saw a one-pass operation?
14. What is a scoring blade?
15. What radial arm saw adjustment does the elevation crank perform?
  - A. Raises or lowers the blade.
  - B. Positions the blade for a miter cut.
  - C. Positions the blade for ripping in the in-rip mode.
  - D. Positions the blade for beveling.
16. The radial arm saw is well suited for \_\_\_\_\_ lumber and wood products.
17. Both band saws and scroll saws have \_\_\_\_\_ blades that allow the saws to cut curves.
18. To saw a workpiece with sharp inside or outside curves that change direction, \_\_\_\_\_ are necessary.

19. Adjusting the top wheel on a band saw allows the operator to control \_\_\_\_\_.
  - A. blade tension
  - B. alignment
  - C. Both A and B.
  - D. None of the above.
20. Marquetry and inlay can be cut using a(n) \_\_\_\_\_ saw, which has a thin, narrow blade.
21. Describe how to cut pockets on a scroll saw.
22. List four important blade specifications.
23. \_\_\_\_\_ angle refers to the angle at which the front edge of the tooth contacts the material.
24. *True or False?* Carbide-tipped blades can be hand sharpened.
25. List four maintenance operations that, when done periodically, will increase the usable life of saw blades.

### Suggested Activities

1. The typical saw motor in the United States runs at 3450 rpm. Verify this with the nameplate on the motor of your table saw. Using this information and the diameter of your saw blade, calculate the rotational rim speed of your blade. The following formula can be used:
 
$$\frac{\text{Blade dia. (")} \times 3.14}{12} \times \frac{\text{rpm} \times 60}{5280}$$

= rim speed in miles per hour (mph)

How many miles per hour are the teeth traveling? Given a blade with 60 teeth, how many times per second does the same tooth pass through the material? Share your calculations with your instructor.
2. Obtain the four different circular saw blade types described in this chapter. Install each in a table saw, one at a time, and crosscut a piece of solid stock at partial depth. Compare the cut profiles as well as the quality of each cut. Share your observations with your instructor.
3. The inclusion of flesh-sensing technology has created a great debate within the industry about whether or not this should be required on all table saws. Using the Internet as a resource, research the debate. Prepare a written argument stating whether you are for or against requiring table saws be equipped with this technology. Share your report with your class.



Courtesy of Tadsen Photography for Madison College

The table saw is the most commonly used machine for ripping stock to size in small to medium operations.